

Evolving Building and Industrial Fieldbus to a Unified Ethernet Infrastructure

By Panduit and Fluke Networks



Introduction

Ethernet technology has evolved to become standardized in almost every industry for automation control. In many of these industries, controllers are configured to communicate upstream over Ethernet but ingest data using RS-485 as well as other serial and analog physical layers. IEEE Single Pair Ethernet (SPE) standards like IEEE 802.3cg, IEEE 802.3bu, and related standards currently in development are expected to continue the march forward for Ethernet technology in operational equipment. These standards allow Ethernet communication and powering over a single twisted pair of conductors, where single pair conductors previously were the realm of serial and analog communications.

With the evolution of technology comes the need to transition actual applications from legacy technologies to Ethernet-based solutions. Experts think this transition will occur over a period of 5-10 years. Given this transition, how are end users to prepare for this future technology? Can they re-use existing legacy infrastructure and topologies for new Ethernet-based single pair devices? If they are installing state-of-the-art serial and analog devices today, can they use Ethernet-capable infrastructure to do so? This white paper will evaluate the use of legacy cabling and topologies for Single Pair Ethernet (SPE) applications, and the use of Single Pair Ethernet systems for legacy applications.



Fieldbus Networks and Topologies

There are several similarities between industrial and building automation networks. It's useful to examine these similarities as a precursor to discussing specific fieldbus systems. Fieldbus networks have these general characteristics:

- They measure and control variables relating to the manufacturing processes, the comfort and safety of workers, and many other elements of the modern facility
- Edge devices (e.g., sensors, actuators) traditionally connect to the OT network using legacy protocols; many use RS-485 physical layer, with 18 AWG shielded twisted pair as a common media choice
- They don't always use connectors, with connections commonly made on terminal strips (aka screw terminals); these connections are highly dependent on workmanship to achieve acceptable performance
- They frequently have long reach at low data rates, e.g., RS-485 over 1,000 meters at 31.2 kb/s
- OT network wiring does not follow the voice and data network pathways or conform to link lengths found in the voice and data networks
- Sometimes, they also deliver a small amount of power (e.g., $\leq 1\text{W}$) that would require a larger wire gauge, up to 18 AWG.

Serial and Analog Communication Systems

What follows is a summary of several communication systems, their topology, physical infrastructure, and details around how they are used in industrial and/or building networks.

HART® (Highway Addressable Remote Transducer) Communication Protocol

HART is an open standard used globally in the process industry and has a large installed base of products. HART sends and receives digital information using analog wiring (4-20ma traditional) between smart devices and control systems. The analog process value is sent over the same wire that the digital signal is sent. HART allows the preservation of existing analog instrumentation and plant wiring.

Digital information superimposed by HART over the analog signal provides diagnostic and maintenance data. Point-to-point topology is the most common way of connecting HART instruments to control systems, but multi-drop can also be used. While multi-drop networks require more design work, the update rate is much slower. Because of electrical considerations, the analog signal for the process value can no longer be used, so it operates as an all-digital network. In theory, the maximum transmission length of the HART protocol is up to 3,000 meters but this depends on the number of devices and the electrical characteristics of the cabling design. Field device installations are typically in the range of 10 to 50 meters. RS-485 type cable is commonly used for HART networks; typical installation includes a shielded single pair 22 AWG cable. Longer runs would include a larger wire gauge, up to 18 AWG.



Fieldbus			
	Bandwidth	Longest Reach 3,000m	Highest Rate 1,200 bps
HART	Topology	Point to point (multi-drop optional) 	
	Infrastructure	 18 to 24 AWG twisted pair (e.g., 3105a, 9841)	 Screw terminals

Figure 1: Chart summary on HART Protocol

BACnet MS/TP

BACnet MS/TP is a protocol widely used for building automation applications. In North America, BACnet protocols have dominant market share for building automation applications. BACnet MS/TP (Master-Slave/Token-Passing) protocol is a peer-to-peer network based on token passing with multiple masters. A token is a packet of information that is passed between devices on a network. The BACnet MS/TP fieldbus uses RS-485 as the physical layer standard for data transmission. The cable is a shielded (foil or braided), twisted pair cable with characteristic impedance between 100 and 130 ohms. Communication wiring is set up in a linear bus, also known as a daisy chain. This means that there is one main cable and the other network devices are connected directly along its path, as shown in Figure 2. A BACnet MS/TP fieldbus network has a maximum cable distance of 1,219m (4,000 feet) with 18 AWG wire. Active devices called repeaters may be used to extend the trunk length.

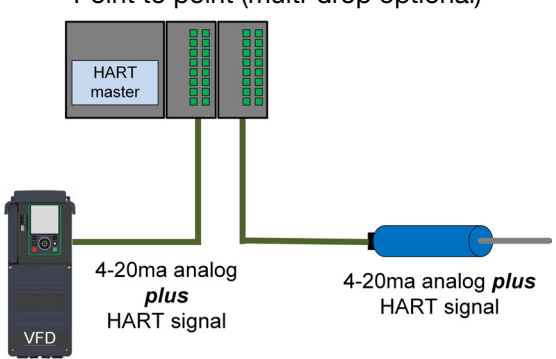

Fieldbus			
BACnet MS/TP	Bandwidth	Longest Reach 76,800 bps @ 1,200m	Highest Rate 115,200 bps @ 1,000m
	Physical Layer	ANSI/TIA-485-A (commonly referred as RS-485)	
	Topology	Daisy Chain / Bus 	
	Infrastructure	 18 to 24 AWG twisted pair (e.g., 9841, 3106A)	 Screw terminals

Figure 2: Chart Summary for BACnet Protocol

Traditional Analog

Before digital fieldbus technology was mainstream, most networks relied on basic analog communication. This communication was often a one-way signal from a controller to a device that provided a direct current electrical reference in the form of 0-10 volts DC or 4-20 mA. Physical media for this signal is a shielded twisted pair cable, typically either 22 AWG or 18 AWG, and connected by point-to-point wiring. Wiring is commonly connected with screw terminals, spring-loaded terminal strips, or some type of insulation displacement connection. Shielded cable is used to reduce electrical disturbance from other devices. PLCs and controllers use filters to isolate the true signal. Voltage signals are limited in length due to voltage drop over the cable. General recommendations are to not exceed 50 feet for voltage signals, e.g., 0 – 10 VDC, and 500 feet for current signals, e.g., 4 - 20 mA. However, much longer distances can be accomplished by calculating the resistance of the entire analog channel and optimizing the design.

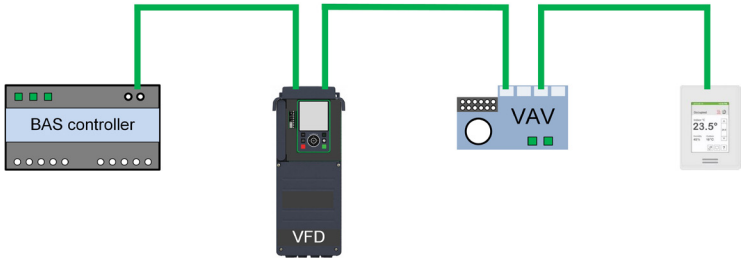
This setup is electrically robust and therefore a wide array of cables can be used. When properly installed, analog systems work well, are cost-effective, and as a result, they are still being used today. Analog signal interfaces are typically used in applications like continuous position sensors and reference signals (speed, position, etc.). The figure below illustrates two analog signal examples: using an analog input signal to control the speed of a variable frequency drive and monitoring position with a sensor that sends an analog signal back to the controller. This setup is very cost-effective but provides limited functionality. Analog systems are limited on the amount of data and control information that is available therefore fieldbus technologies are a preferred alternative.



Fieldbus			
	Bandwidth	Reach 500m or greater	Highest Rate Continuous
Analog	Physical Layer	0 – 10 VDC or 4 – 20 mA	
	Topology	<p style="text-align: center;">Point to Point</p> 	
	Infrastructure	 18 to 24 AWG twisted pair (e.g., 8761)	 Screw terminals

Figure 3: Chart Summary for Analog communications

PROFIBUS DP/PA

There are two different types of PROFIBUS, and each has its own physical layer requirement. PROFIBUS DP (Decentralized Peripherals) is based on an RS-485 network supporting various applications including factory automation, motion control, and non-hazardous locations in process automation. PROFIBUS PA (Process Automation) is designed for hazardous, explosion-proof, and intrinsically safe applications and to co-exist with PROFIBUS DP network. Profibus DP and PA use the exact same protocol but utilize a different communications physical layer. Both variants support different topologies. Although PROFIBUS DP is based on RS-485 it is recommended to use a slightly different cable (150 ohms characteristic impedance) than typical RS-485 networks (nominally 120 ohms characteristic impedance).

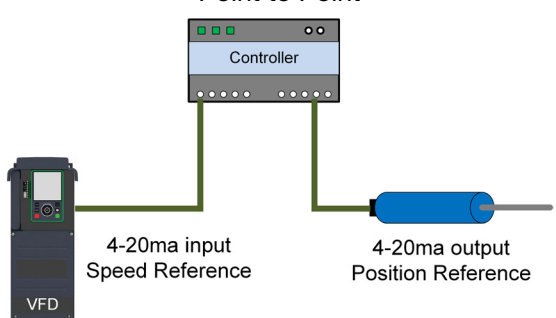
PROFIBUS PA physical layer is Manchester encoded bus powered (MBP) and transmits data and power over the same two wires. This physical layer allows for use in hazardous environments since MBP supports intrinsically safe operation. Typically, PROFIBUS PA and DP are used in the same network but require an intermediate device due to electrical differences in the physical layer. PROFIBUS PA utilizes IEC 61158-2 Type A cable that is typically 18 AWG shielded, the same type of cable used for Single Pair Ethernet applications. A maximum distance of up to 1,200 meters can be achieved, but at a lower data rate, about 9.6 kbps. In order to achieve the 12Mb/s transmission rate, the cabling must be limited to around 100 meters.

Fieldbus			
PROFIBUS DP & PA	Bandwidth	Longest Reach 1,200m (DP)	Highest Rate 12Mb/s (DP) 31.25 kbits/s (PA)
	Physical Layer	MBP or ANSI/TIA-485-A	
	Topology		
	Infrastructure	 18 to 24 AWG twisted pair IEC 61158-2	 Screw terminals

Figure 4: Chart Summary for PROFIBUS Protocols

FOUNDATION Fieldbus™ H1

The term “fieldbus” is general and refers to any bus that connects field devices. FOUNDATION Fieldbus (FF) is a specific fieldbus that was originally intended to enhance and replace 4-20mA analog technology. FF is predominately used in oil, gas, and petrochemical industries, as well as the process industry. FF is an all-digital, publisher-subscriber communications network, which can also be used in hazardous locations, similar to PROFIBUS PA. Topologies for FF include point-to-point, trunk and spurs, daisy chain, tree, or a combination of these supported technologies.

FF recommends cable meeting IEC 61158-2 requirements, Type A variant for optimal performance. Other variants of the IEC 61158 requirements (e.g., Type B) can be utilized but the system speed and/or transmission distance will be derated. Most optimized FF installations are set up with IEC 61158-2 Type A cable, a shielded 18 AWG with a drain wire cable. This is the same construction used for Single Pair Ethernet.



Fieldbus			
FOUNDATION Fieldbus	Bandwidth	Longest Reach 1,900m	Highest Rate 31.25 kbits/s
	Physical Layer	MBP (Manchester encoded bus powered)	
	Topology	<p style="text-align: center;">Fieldbus Daisy Chain Topology</p> <hr/> <p style="text-align: center;">Fieldbus Bus Topology</p>	
	Infrastructure	 18 to 24 AWG twisted pair IEC 61158-2 Type A	 Screw terminals

Figure 5: Chart Summary for FOUNDATION Fieldbus Protocol



Validation of Fieldbus Networks and Futureproofing

In legacy fieldbus networks, there is a strong culture around commissioning and validation of entire systems. Validation is typically performed at the system function level. Legacy fieldbus network validation procedures do not typically measure and evaluate the performance of the physical infrastructure communication network as is done with high-performance Ethernet communication networks.

Typical steps to validate a fieldbus physical infrastructure:

- Use specific brand components and cabling, proven in the application and/or recommended by the automation manufacturer
- Run continuity and signal quality tests
- Plug in your devices and validate everything is recognized and responsive
- Operate at full communication load for a length of time without failure

Evaluating fieldbus systems in this way has worked for years, however it exposes the user to three risks:

- First, since these procedures are functional performance evaluation instead of cabling infrastructure validation, the system is validated to the functions that it is designed to perform, not necessarily future upgrades to the fieldbus system. Said another way, legacy fieldbus commissioning procedures do not develop baseline installation data that can be used to ascertain physical infrastructure suitability for future applications and/or upgrades.
- Second, since the validation is performed as an entire system, it can be difficult to diagnose whether problems that arise are related to the physical infrastructure, or if the system has an equipment malfunction. Building full confidence in system performance can take months of frustrating debug followed by years of successful operation.
- Third, the validation only proves operation under the conditions when it is performed. There is no assurance that the cabling will continue to function properly under different conditions (thermal, electromagnetic interference, humidity, etc.).

Evolving to Next Generation Fieldbus

Another way to approach evaluation of fieldbus and analog communication systems is to make use of test methods specifically designed to measure high-frequency data transmission performance across single twisted pair cabling.

Initial results show that Single Pair Ethernet test methods and parameters as listed by IEC 61156-13 and -14 (draft) and TIA-568.5 (draft) can be used to validate the performance of fieldbus and I/O infrastructure. These tests provide objective, measurable performance of cabling over a wide range of frequencies, which helps to identify to what extent a legacy cabling system will support current and future applications.

Using Fieldbus Cable for Next Generation Communications

Fieldbus systems have already begun to migrate toward Ethernet. As recently as 2018, new installations of industrial automation nodes were split evenly between legacy fieldbus and industrial Ethernet nodes. Three years later, data from the same source shows that industrial ethernet nodes are now more than 65 percent of installed nodes. In multiple industries, standards bodies responsible for communications protocols have evolved their standards so that they support both Ethernet and legacy fieldbus physical layers. ODVA developed EtherNet/IP to serve users' industrial Ethernet needs, designed to integrate seamlessly with its foregoing legacy fieldbus protocols like DeviceNet and ControlNet via CIP (Common Industrial Protocol). Another example, PROFINET International have taken the fieldbus protocol PROFIBUS and developed an Ethernet-based system called PROFINET. Also, ASHRAE, the organization that publishes the BACnet standard, developed BACnet/IP, which transports a BACnet message inside of an Ethernet frame. This migration has progressed for most of the industrial and building automation fieldbus protocols, so that almost every application can operate over a standardized Ethernet physical layer – whether using 2- or 4-pair copper or fiber optic infrastructure. Since serial fieldbus has typically used single twisted pair cabling, this evolution has typically required installation of new purpose-built Ethernet infrastructure, and removal of serial 1-pair infrastructure.

Organization	Legacy Fieldbus	Industrial Ethernet
ODVA	ControlNet, DeviceNet	EtherNet/IP
Fieldcomm Group	FOUNDATION Fieldbus H1	FOUNDATION Fieldbus HSE
Fieldcomm Group	HART	HART IP
Profi International	PROFIBUS DP/PA	PROFINET
ASHRAE	BACnet MS/TP	BACnet/IP
KNX	KNX	KNXnet/IP

Figure 6: Legacy Fieldbus Protocols and their newer Industrial Ethernet equivalents



One obvious benefit of Single Pair Ethernet adoption is industrial Ethernet applications can now run over single twisted pair infrastructure that has very similar construction to fieldbus cabling. There is a compelling possibility to use the existing serial infrastructure for an upgrade from legacy fieldbus to Ethernet. This possibility is compelling because eliminating new cable installation substantially reduces the complexity of an upgrade. In an ideal case, this should be possible.

Here are the key differences between serial fieldbus and Single Pair Ethernet cabling requirements, to be aware of for an upgrade:

- 1) SPE operates at a broader range of frequencies than legacy cabling. Legacy cabling was built for operational frequencies less than 100 kHz; Single Pair Ethernet networks running at 10 Mb/s operate at up to 20MHz. This broad discrepancy in operating frequencies is magnified by future SPE specifications which will be faster than 10 Mb/s.
- 2) SPE and serial cabling both typically require a nominal impedance of 100 Ohms. However, the increased frequency range used by SPE means that impedance requirements must be met across the frequency range.
- 3) An increased frequency range means that the cable must meet twisted pair balance requirements and return loss across the frequency range.

Since fieldbus cabling was designed to operate at lower frequencies than the future systems, it will be important for users to test any installed cabling systems for upgrade to Ethernet-based fieldbus networks.

Using Single Pair Ethernet for Fieldbus and I/O

As Single Pair Ethernet expands throughout the industry, there is an opportunity for fieldbus cabling to prepare for the incoming SPE technology. Common fieldbus technologies in use today (such as BACnet, FOUNDATION Fieldbus H1, HART, PROFIBUS PA/DP) are deployed with a single pair cable that is in some ways similar to SPE cable. So, does this mean that SPE cable can be used for fieldbus networks? In many cases, the answer may be yes.

As previously mentioned, one of the key differences between SPE and fieldbus cable is the ability to perform at higher frequencies. Fieldbus cabling often references the IEC 61158-2 standard that covers industrial communication networks, fieldbus specifications, for the physical layer. Two common types of specifications within IEC 61158-2 are type A and type B. For example, PROFIBUS PA and FOUNDATION Fieldbus references IEC 61158-2 type A, due to the use of a Manchester encoded bus powered (MBP) physical layer. On the other hand, PROFIBUS DP and HART are based on RS-485 and therefore, cable specifications are more like the IEC 61158-2 Type B variant. SPE cable is similar in design to these fieldbus cables but follows SPE cable standard IEC 61158-13 (draft). This standard focuses on the higher frequency testing that is inherent with SPE and not in traditional fieldbuses. Initial testing against this standard shows that SPE cable can be used in place of fieldbus type A applications. However, the inverse may not be true.

Since type A cable addresses an impedance level testing up to 20 MHz (in addition to other specifications), it pairs better than type B cable which has different testing requirements and design. Type A cable is also specified for Ethernet- APL (advanced physical layer) networks. Type B specification is limited in frequency, speed, and length when compared to type A. Table 1 is taken from the IEC 61158 standard to illustrate the differences between the type A/B maximum cable length for the different transmission speeds encountered in legacy fieldbus networks. The most reliable method is to test the network in the field, based on the requirements that are needed for the network. However, based on testing and specifications, SPE cable is an alternative to IEC 61158-2 type A cable applications. Utilizing SPE cable for fieldbus applications provides a future proof physical layer.

Table 1: Maximum cable length of cable type A and cable type B for different transmission speeds.

Item	Unit	Value								
		9.6	19.2	93.75	187.5	500	1500	3000	6000	12000
Data rate	kbit/s	9.6	19.2	93.75	187.5	500	1500	3000	6000	12000
Cable type A	m	1200	1200	1200	1000	400	200	100	100	100
Cable type B	m	1200	1200	1200	600	200	70	Not permissible		



Structured Cabling

There are two options for connecting copper network cable: structured and direct attached (point-to-point). The preferred method for reliability and longevity is a standards-based structured cabling setup. Structured cabling is a planned cabling system that systematically lays out the cable management necessary for communications, including voice, data, video, and control for today and the future. Structured cabling started within enterprise and data center deployments, but has now expanded to many industries, including building automation and industrial systems. Figure 7 shows the difference between a direct-attached configuration (top) and a traditional structured cabling configuration (bottom).

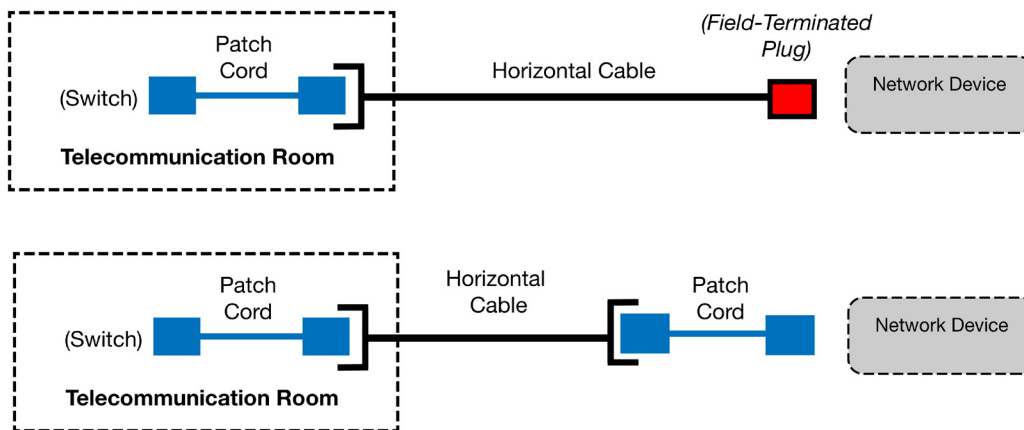

Figure 7: Structured Cabling for Ethernet Networks

Benefits of Structured Cabling

- Eliminates proprietary cabling
- Redundant pathways reduced
- Low voltage cabling becomes managed
- Provides migration path to IP devices
- Asset control
- Reduced labor and faster deployment
- Moves/adds/changes are easier and cost less
- Testable links to ensure performance
- Patching to recover rapidly from unplanned outages

In general, point-to-point is less resilient than structured cabling because testable links do not exist, spare ports cannot be installed, and the use of stranded conductors means reduced reach. Also, in a point-to-point system, a failed cable must be replaced to restore operation. However, good use cases exist for point-to-point connectivity, such as short single-connection runs. Therefore, typical installations will include both structured and point-to-point cabling. Structured cabling is utilized in the industrial space for electrically connecting field devices. This is the same principle as structured cabling for networks but with a different cable. The cable for this consists of standard electrical machine tool wire and it is connected using terminal strips, see figure 8.

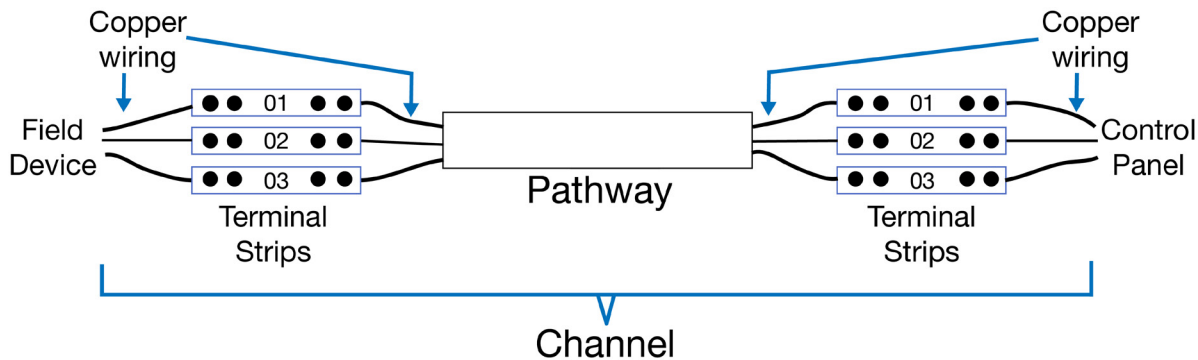

Figure 8: Typical cabling structure for fieldbus

A structured copper network channel is formed with a patch cord plugged into the device and the other end of the patch cord plugged into a jack in a patch panel. The jack is terminated to a copper horizontal cable that extends to a jack on the other end. A patch cord is plugged into the jack, and the other end of the patch cord is plugged into the device, completing the channel, as shown in Figure 7. This configuration is common for 4-pair Ethernet and can provide the same benefits for SPE.

Validating Single Pair Communication Networks

Testing single-pair networks can provide a benefit to end users, whether those single-pair communication networks are used in building or industrial automation, and whether those networks are used to communicate over the Internet Protocol stack or using serial fieldbus communications.

All communication networks – whether Ethernet, fieldbus, or analog – applications require the electrical signals transmitted across the cabling to reach the receiver without unacceptable loss of signal strength or experiencing too much noise. If the signal to noise ratio is too high, the application will not function correctly, resulting in data loss and the need to retransmit.

By testing the cabling, independent of the active equipment, it is possible to ensure that an installation will support single-pair applications such as 10BASE-T1L, Ethernet-APL, or even more basic communication devices when any compliant equipment is running on the network.

Testing of cabling in this way can identify non-compliant cable or connectors, as well as issues caused by workmanship or topology during the installation (e.g., over entire channel).

The application requirements developed by IEEE have been extended into cabling installation requirements from TIA and ISO. These cabling requirements include the ability to test individual elements of the channel without need for the completed channel or installation. Benefits of these installation requirements include simplified design, more system flexibility, and improved reliability.

These cabling documents also provide requirements for patch cords which can be added to a compliant cabling installation, yet still assure SPE support.

This is a marked change from traditional fieldbus networks, which as noted before do not have channel test performance requirements, and so cannot be readily evaluated except by the installation and operation of equipment on the networks.

Some of the key benefits of testing include:

- Standards-based interoperability
- Assured application/equipment support
- Documented performance
- Warranty submissions
- Reduced rework and installation costs
- Ensured remote powering levels
- Expansion of the system to future communication standards operating at higher frequencies

Best Practices for Testing

For maximum confidence that the cabling will support SPE, a calibrated tester should be used that meets the requirements of TIA-5071/IEC 61935-4, to characterize the cabling according to the link or channel specification needed for your application.

The tester will measure all the relevant transmission parameters needed to ensure operation, as well as locating any defects due to materials or workmanship, thus decreasing the time required for commissioning and troubleshooting the network.

Cable performance is optimized by matching the cable specifications to the electrical characteristics of the system. There are several factors to consider, impedance matching being one of the most important. The installed cable will become a part of the system that is connected to the sending/receiving electronics. Impedance matching assures that the cable provides the optimal path for the electronics to transmit signals back and forth. A good impedance match will maximize the power transfer and minimize any distortion or signal losses. There is no single cable that works best for different networks; the best cable is the one that is matched to the system design.

Impedance matching can be validated by many testing methods. Insertion Loss (IL) and Return Loss (RL) testing provides a measurement, expressed in decibels, that compares the original signal to what is transmitted therefore outputting a measurement of the difference. These tests are performed across the range of frequencies across which the cable is to be utilized; an important point, since as bandwidth increases, the frequency range increases too. These types of tests can be performed in the field when using a structured cabling approach (see 'structured cabling' section) and using the proper test equipment (see 'best practices for testing' section). These tests will show real-world performance as the system is installed. Testing the cable independent of the active equipment ensures system performance when using complaint equipment. It can also serve as a baseline for future troubleshooting and/or network expansion. Proper design and testing of the physical layer takes the guesswork out of the system's performance. Many protocols that are used today have similar requirements for the physical layer and therefore can be leveraged in the future for other applications. This can only be accomplished with proper design and validation testing.

Single Pair Transmission Parameters

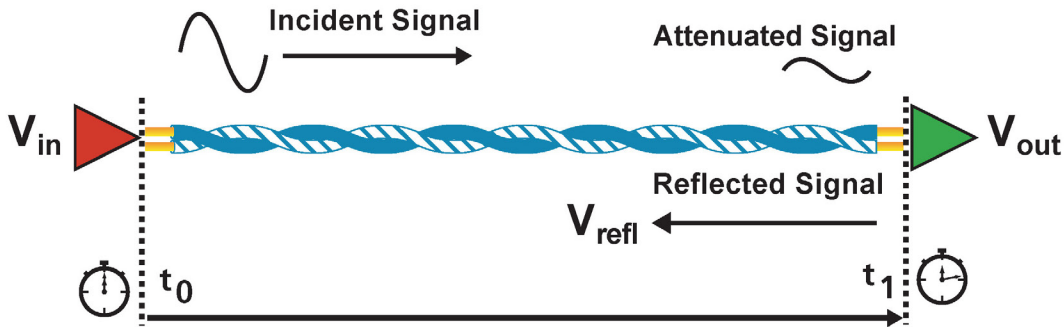

Insertion Loss: $\left[\frac{V_{in}}{V_{out}} \right]$ **Failure:** Excess length, high frequency or temperature, excess return loss, wire gauge too thin, poor cable design.

Return Loss: $\left[\frac{V_{in}}{V_{refl}} \right]$ **Failure:** Mismatched impedance of cable-connector, jack-plug, or cable-cable; untwisting at connector; closely placed connections; asymmetric twisting; high resistance contact; poor cable or connector design.

Propagation Delay: $t_1 - t_0$ **Failure:** Excess length, poor cable design.

Transverse Conversion Loss:

A ratio of the measured common mode voltage on a pair relative to the differential mode voltage on the same pair applied at the same end. TCL indicates if a pair is well balanced and with that has good immunity to external noise.

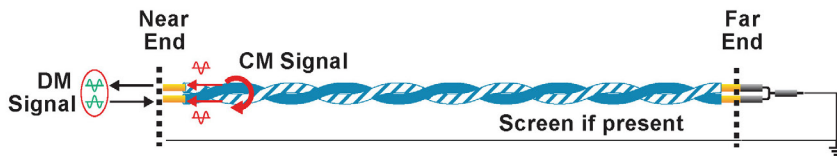

Figure 9: Typical transmission parameters for twisted pair cabling.



Planning and Use of Cabling

SPE doesn't change the way you install your cabling, which increases the potential to re-use some types of installed legacy cabling. This allows for small field switches to connect directly to edge devices (HVAC, mechanical, safety), faster and easier commissioning, and therefore, faster project completion.

Testing of previously installed cabling is recommended. Testing is essential when the original specifications did not consider SPE requirements. The inherent risk for cable reuse, especially in industrial environments, is the electrical and mechanical health of the installed cable. For example, where IEC 61158-2 Type A cable was used for a fieldbus installation which did not consider the SPE requirements, this cable may support SPE. However, there may be some cases where the components used for the fieldbus installation can cause issues. Field testing locates these problems before the network is live, removing the risk of troubleshooting downtime.

Some standards, like the APL Engineering Guidelines, place clear emphasis on the need to ensure legacy cabling compliance to the new specification by testing.

“During the acceptance test the integrity of the cabling should be measured and documented for later use and plant.”

*- Planning, installation, and commissioning
of Ethernet-APL networks - Version 1.0*



SUMMARY

Single Pair Ethernet (SPE) is an important technology to evolve existing analog, serial, and legacy communications applications to a unified Ethernet network. This technology also comes with physical layer test standards, which is useful for physical layer validation prior to equipment start-up.

SPE shows promising results to be backwards compatible with fieldbus cable applications, based on cable construction similarities and operating fieldbus evaluations. This data suggests SPE cable can be used for greenfield fieldbus deployments with the added advantage of futureproofing the migration to Ethernet-based single pair systems.

Legacy fieldbus cabling has similar construction to SPE cabling, but it has not been designed for use at the higher frequencies encountered with SPE. Before a brownfield upgrade to SPE applications, viability for reuse of installed fieldbus cables should be tested. Testing the cabling infrastructure reduces installation times and network downtime. It is important to work with your cabling manufacturer and test equipment provider to ensure that the right testing is performed to establish compliance and application warranty.



**Fluke Networks
World Headquarters**

6920 Seaway Boulevard
Everett, WA 98203

Phone: 425-446-4519



Since 1955, Panduit's culture of curiosity and passion for problem solving have enabled more meaningful connections between companies' business goals and their marketplace success. Panduit creates leading-edge physical, electrical, and network infrastructure solutions for enterprise-wide environments, from the data center to the telecom room, from the desktop to the plant floor. Headquartered in Tinley Park, IL, USA and operating in 112 global locations, Panduit's proven reputation for quality and technology leadership, coupled with a robust partner ecosystem, help support, sustain, and empower business growth in a connected world.

For more information

Visit us at www.panduit.com

**Contact Panduit North America Customer Service by email: cs@panduit.com
or by phone: 800.777.3300**

THE INFORMATION CONTAINED IN THIS ARTICLE IS INTENDED AS A GUIDE FOR USE BY PERSONS HAVING TECHNICAL SKILL AT THEIR OWN DISCRETION AND RISK. BEFORE USING ANY PANDUIT PRODUCT, THE BUYER MUST DETERMINE THE SUITABILITY OF THE PRODUCT FOR HIS/HER INTENDED USE AND BUYER ASSUMES ALL RISK AND LIABILITY WHATSOEVER IN CONNECTION THEREWITH. PANDUIT DISCLAIMS ANY LIABILITY ARISING FROM ANY INFORMATION CONTAINED HEREIN OR FOR ABSENCE OF THE SAME.

All Panduit products are subject to the terms, conditions, and limitations of its then current Limited Product Warranty, which can be found at www.panduit.com/warranty.

* All trademarks, service marks, trade names, product names, and logos appearing in this document are the property of their respective owners.

PANDUIT US/CANADA
Phone: 800.777.3300

PANDUIT EUROPE LTD.
London, UK
cs-emea@panduit.com
Phone: 44.20.8601.7200

PANDUIT SINGAPORE PTE. LTD.
Republic of Singapore
cs-ap@panduit.com
Phone: 65.6305.7575

PANDUIT JAPAN
Tokyo, Japan
cs-japan@panduit.com
Phone: 81.3.6863.6000

PANDUIT LATIN AMERICA
Guadalajara, Mexico
cs-la@panduit.com
Phone: 52.33.3777.6000

PANDUIT AUSTRALIA PTY. LTD.
Victoria, Australia
cs-aus@panduit.com
Phone: 61.3.9794.9020